

CONTROL PANEL

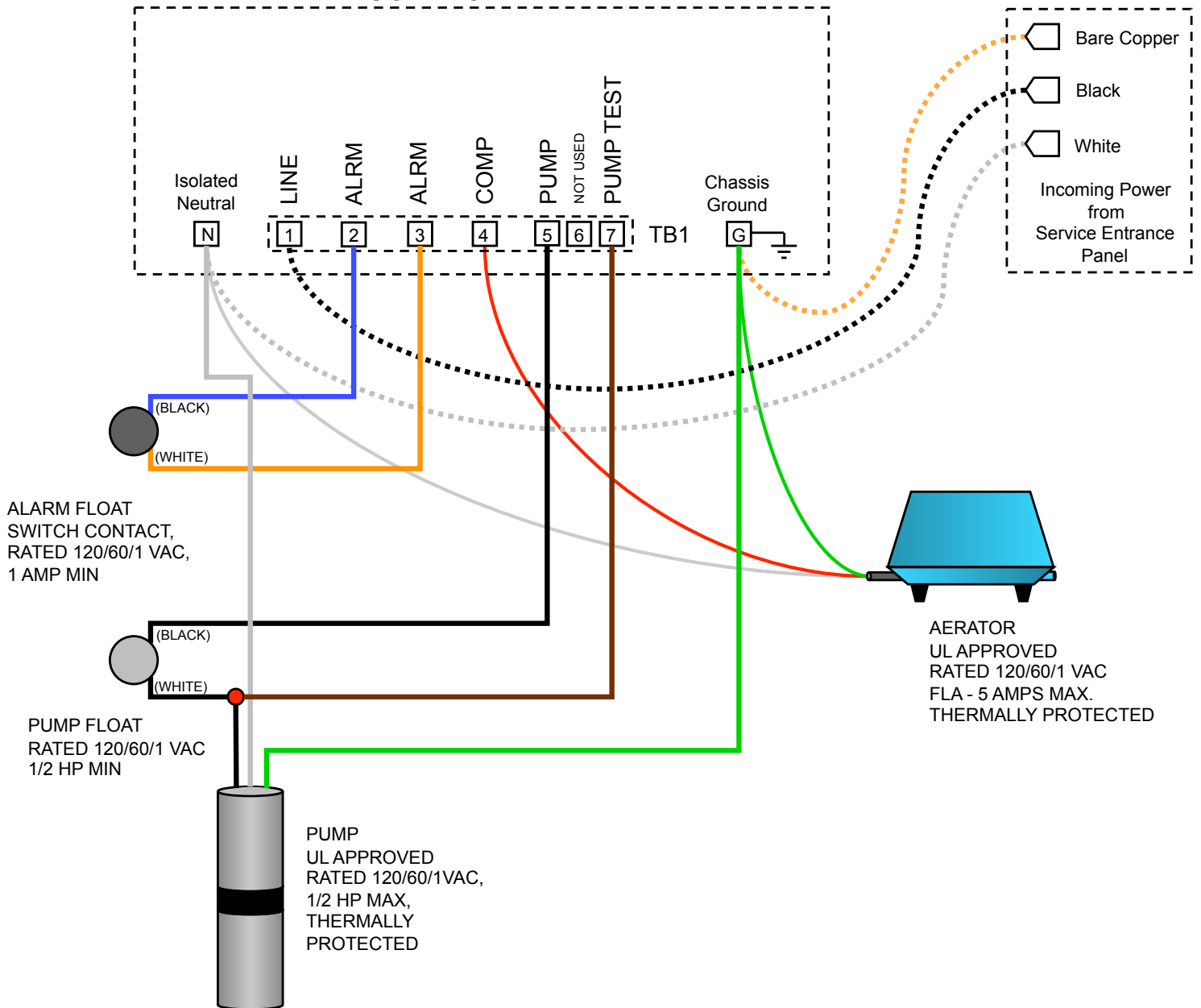

Notes for field installed components:

1. Main Disconnect, Branch Circuit Protection, wiring and external components to be provided by installer.
2. Field wiring - #12 – #10 AWG, 60°C min, use copper conductors only.
3. Field installed conduit fittings must be rated for use with Type 4X Enclosure.
If used, metal conduit fittings must provide means to bond conduit to ground terminal.
4. Torque Terminal Block, Neutral and Ground screws to 15 – 20 in-lbs.
5. **Conduit openings must be sealed around wiring with an electrical grade (non-corrosive) sealant to prevent potentially harmful vapors from entering the control panel.**

Copyright Notice

C-IP-001

All information contained on this page is proprietary to Ecological Tanks, Inc. and no part of this information may be reproduced, stored in a retrieval system or transmitted in any form or by any means, electronic, mechanical, photocopying, recording or otherwise without the prior written permission of Ecological Tanks, Inc..

